

# NPV

# DUCO Bidirectional Perimeter Seated Full Port Cavity Free Design

## Series 200

### Features and Benefits:

1. Perimeter seating guarantees bi-directional bubble tight shutoff
2. Elastomer seat is mechanically retained between body halves preventing movement or separation from the body, unlike standard o-ring seated valves
3. Full port cavity free body design prevents de-watering of pulp stock and is ideal in slurries, powders, plastics and other solids handling applications
4. Precision machined body halves serve as scrapper blades, which extend the life of the packing system
5. Two-piece body design simplifies repair/replacement of gate, packing, seat ring and topworks assembly
6. Non-rise stem design eliminates potential safety hazard caused by rising stem valves and performs better in high vibration areas
7. All NPV/DUCO Valve body castings are of 317SS (CG8M)
8. All external valve components- stanchions, bolting, bridge, stem, clevis, packing follower- are stainless steel construction which eliminates external corrosion
9. Precision machining of the stuffing box with the live-loaded packing in conjunction with an additional Viton O-ring provides for a very dependable and adjustable packing system
10. Two piece body design allows for option to use the standard perimeter seat or replaceable cartridge seats depending on requirements of application

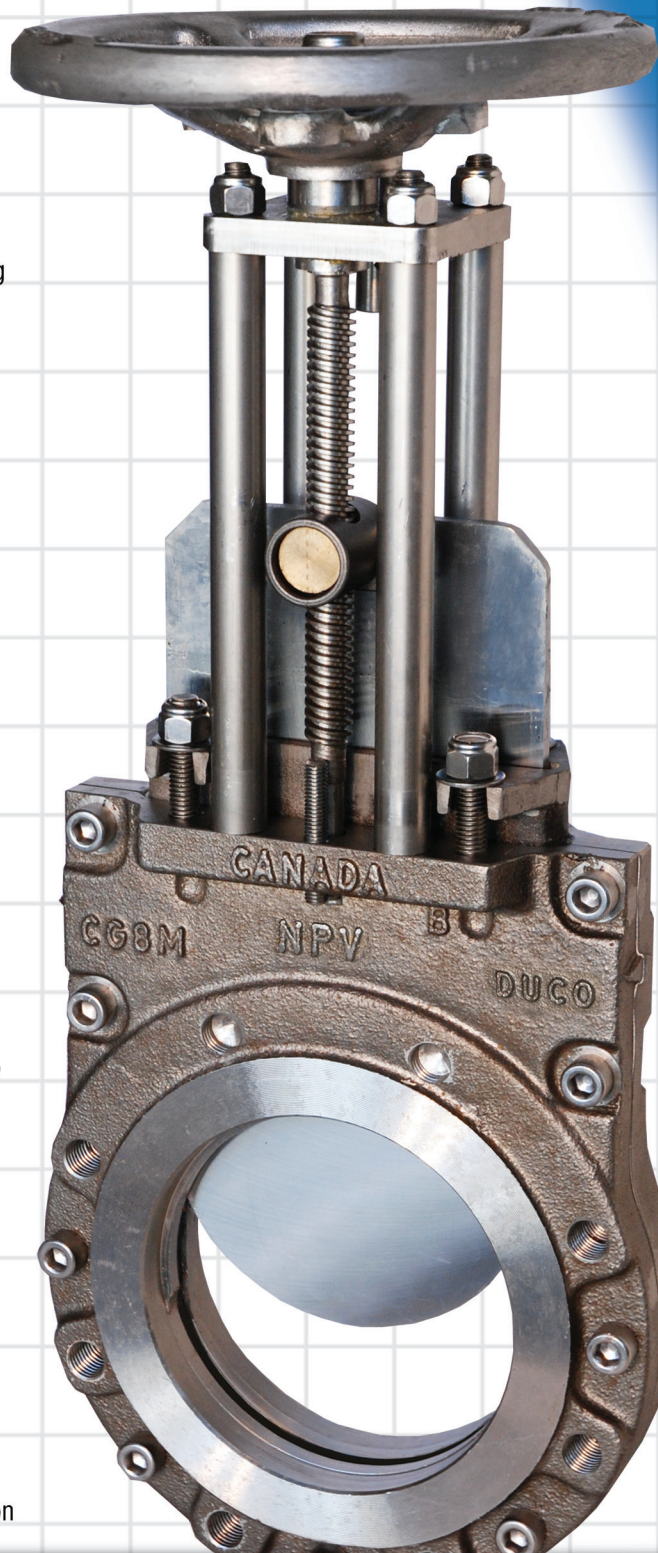

Full port, perimeter seat



Manual lockout

### REPLACEMENT SEAT CARTRIDGES:



# NPV DUCO Bidirectional Perimeter Seated Full Port Cavity Free Design

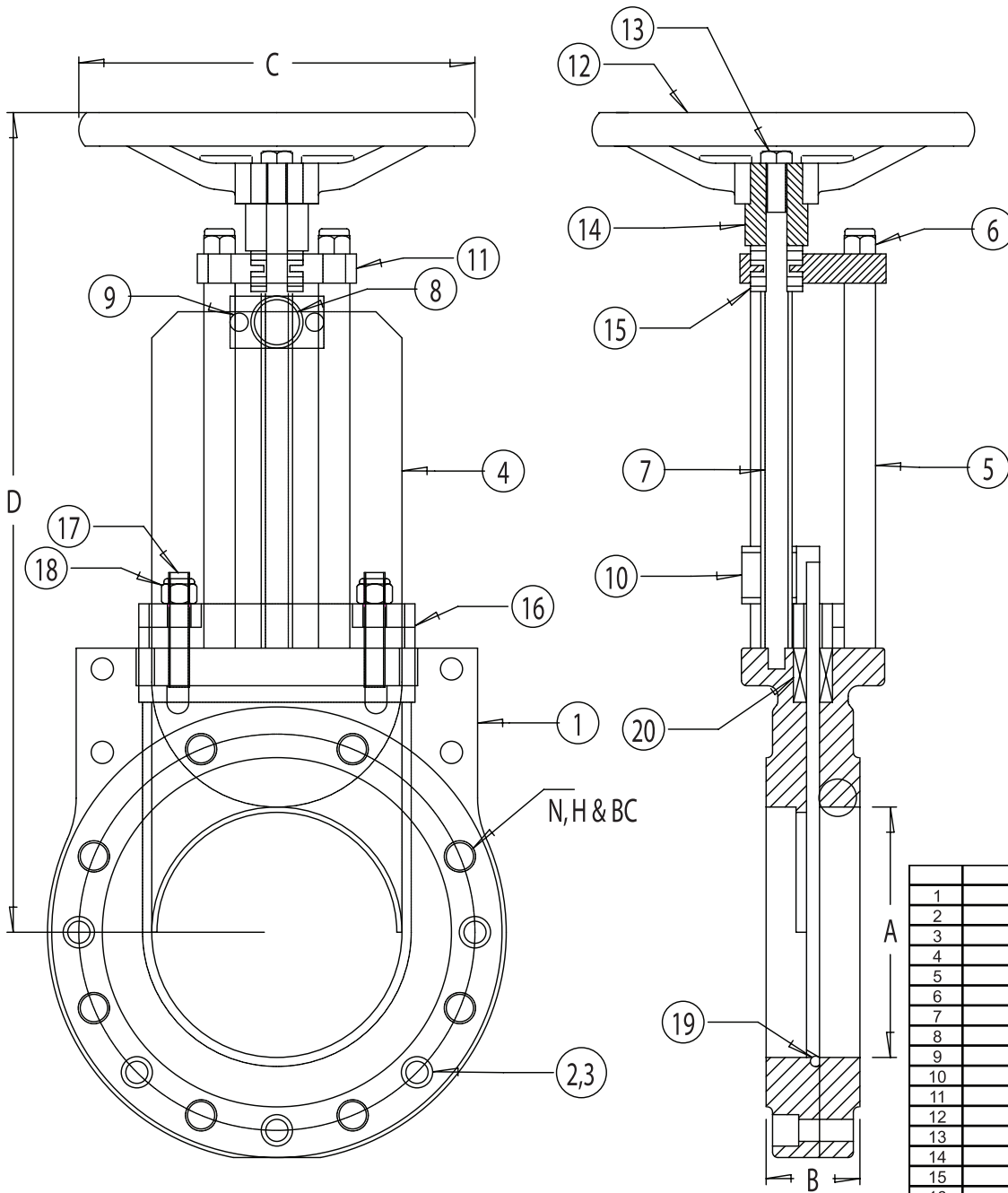

	PART NAME	MATERIAL
1	BODY	CG8M (317 S.S.)
2	BODY BOLTS	18.8 S.S.
3	BODY NUTS	18.8 S.S.
4	GATE	316L S.S.
5	STANCHION	303 S.S.
6	NYLOK NUT	18.8 S.S.
7	STEM	303 S.S.
8	COUPLING	303 S.S.
9	COUPLING BOLT	18.8 S.S.
10	STEM NUT	660 BRONZE
11	BRIDGE	304 S.S.
12	HANDWHEEL	ALUMINUM
13	HANDWHEEL BOLT	18.8 S.S.
14	YOKE	303 S.S.
15	BEARINGS	S.S. BALL BEARINGS
16	GLAND	CG8M (317 S.S.)
17	GLAND STUDS	18.8 S.S.
18	GLAND NYLOK NUT	18.8 S.S.
19	O-RING	VITON
20	PACKING	SYNTHETIC (2-12PH)

\*Body & Gate also available in: 254SMO, 2205 Duplex, Titanium, Hastelloy & others upon request

	3"	4"	6"	8"	10"	12"	14"	16"	18"	20"	24"	30"
A	3"	4"	6"	8"	10"	12"	14"	16"	18"	20"	24"	28 5/16"
B	2"	2"	2 1/4"	2 3/4"	2 3/4"	3"	3"	3 1/2"	3 1/2"	4 1/2"	4 1/2"	4 1/2"
N(HOLES)	4	8	8	8	12	12	12	16	16	20	20	28
H(TAP)	5/8" - 11	5/8" - 11	3/4" - 10	3/4" - 10	7/8" - 9	7/8" - 9	1" - 8	1" - 8	1 1/8" - 7	1 1/8" - 7	1 1/4" - 7	1 1/4" - 7
BC	6"	7 1/2"	9 1/2"	11 3/4"	14 1/4"	17"	18 3/4"	21 1/4"	22 3/4"	25"	29 1/2"	36"
C	7 1/2"	7 1/2"	9"	11 3/4"	11 3/4"	15 3/4"	15 3/4"	15 3/4"	20"	20"	23 5/8"	26 3/4"
D	15 1/2"	17"	20 1/4"	25"	29"	32 7/8"	36 7/8"	44 1/2"	48 1/4"	52 7/8"	64"	72 1/2"